

inControl
water systems

MONSOON

FORCE

SERIES

Simplex Pump System

FEATURES

Disconnect Switch

Power service supplied to and connected here.

VFD Environmental Rating Type 4X

VFDs supply constant irrigation pressure at varying flow rates while protecting the pump and motor from irregular operation.

Heated and Fan Cooled Insulated Enclosure

Pressure Transducer

Check Valve

Isolation Valves on Suction and Discharge

Pump and Motor

Close couple pump end with O.D.P. motor
15 HP, 20 HP, or 25 HP.

Suction Flange (connection typ.)

Point of connection to water supply for pump station.

Discharge Flange (connection typ.)

Point of connection to irrigation main line or other service lines.

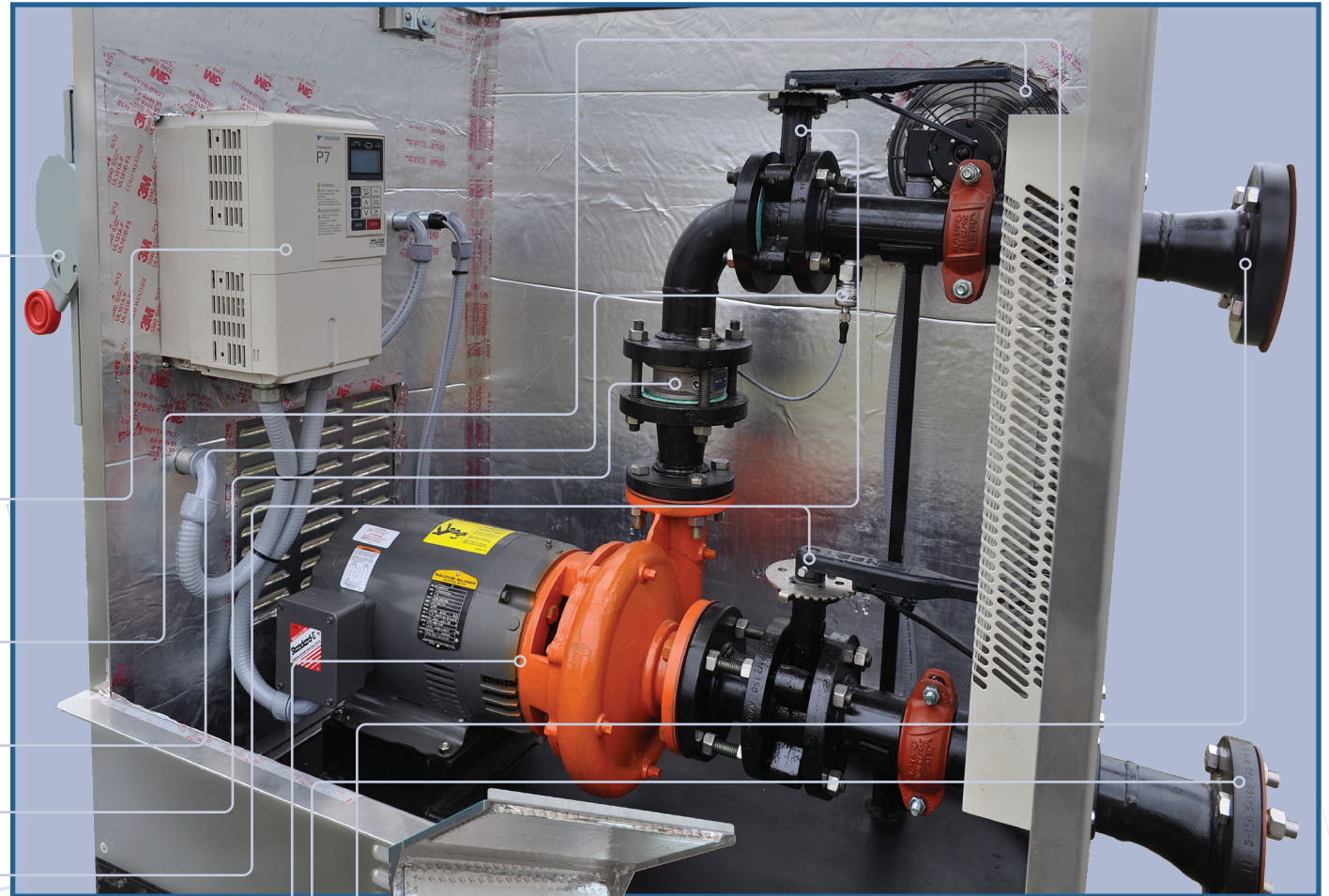

AVAILABLE OPTIONS

Custom enclosure and skid sizes

Totally Enclosed fan Cooled Motor (T.E.F.C.)

Self Cleaning Filter

Level Controls

Pressure Maintenance Pump

MONSOON FORCE SERIES

FEATURES & BENEFITS

Simplex pump station manufactured by inControl Water Systems.
A stand-alone pump station complete with enclosure and Variable Frequency Drive.

SUITABLE FOR: FLOODED-SUCTION • SUCTION-LIFT • BOOST APPLICATIONS.



- » Single pump configuration (15 HP, 20 HP, or 25 HP)
- » Commercial usage
- » Operates on 208, 240, or 480 Volt; Single-Phase or Three-Phase Power
- » Steel skid, painted w/ direct to metal corrosion resistant paint
- » All equipment is self-contained inside aluminum enclosure
- » Pressure Activated and requires no wired connection to irrigation system
- » Variable Frequency Drive (VFD)
- » Packaged pump station that provides easy plug and play installation
- » UL listed componentry
- » Optional Pressure Maintenance Pump

CONTROL PACKAGES

inCon-trol Water Systems is a UL 508A listed panel shop. Which means inCon-trol, not a third party company, designs, programs and manufactures every pump station control panel. By being the control panel designer and manufacturer, inCon-trol is able to troubleshoot most issues directly over the phone. Customers get instant feedback from the designer and programmer, instead of frustrating wait times from a third party control's company.

Control panels come in two different options, the Basic Control Package and the Complete Control Package.

The **Basic Control Package** comes with all components needed for a fully functional automatic pump station.

The **Complete Control Package** comes with these added features: Touch Screen Interface, Programmable Logic Controller, Remote Access Capabilities, Flow Meter, Level Controls, Data Logging, and Text/Email Alerts. Text/Email alerts require internet connectivity. Optional Cellular Modem available.

BASIC CONTROL PACKAGE

- » Environmental Rating Type 3R Enclosure
- » Variable Frequency Drive
- » Door Safety Interlocked External Power Disconnect Switch
- » Control Transformer
- » Lightning Surge Protection
- » Thermostat
- » Fan & Heater
- » Pressure Transducer



COMPLETE CONTROL PACKAGE

(Includes all items in Basic Control Package Plus the following)

- » Touch Screen Interface
- » Programmable Logic Controller (PLC)
- » Remote Access System - allows users to login to pump station panel via internet connection

MONSOON FORCE SERIES

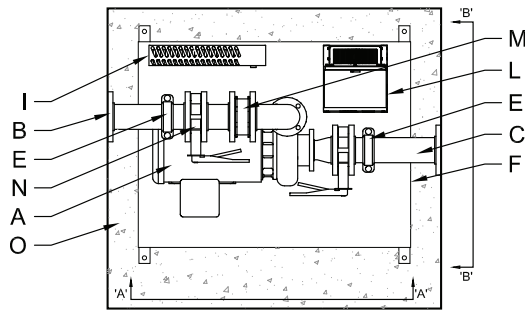

- A. CLOSE COUPLED PUMP/MOTOR
 - B. DISCHARGE PLUMBING - STEEL PIPE
 - C. SUCTION PLUMBING - STEEL PIPE
 - D. PRESSURE TRANSDUCER
 - E. GRUVLOK STEEL COUPLING
 - F. STEEL PUMP SKID - DIRECT TO METAL CORROSION RESISTANT PAINT.
 - G. ALUMINUM ENCLOSURE (INSULATED)
 - H. VENT COVERS
 - I. HEATER
 - J. FAN
 - K. DISCONNECT SWITCH
 - L. VARIABLE FREQUENCY DRIVE
 - M. CHECK VALVE
 - N. BUTTERFLY VALVE
 - O. CONCRETE PAD
- *PUMP STATION SHALL BE PRESSURE ACTIVATED, AND REQUIRES NO ELECTRICAL CONNECTION TO THE IRRIGATION SYSTEM.*

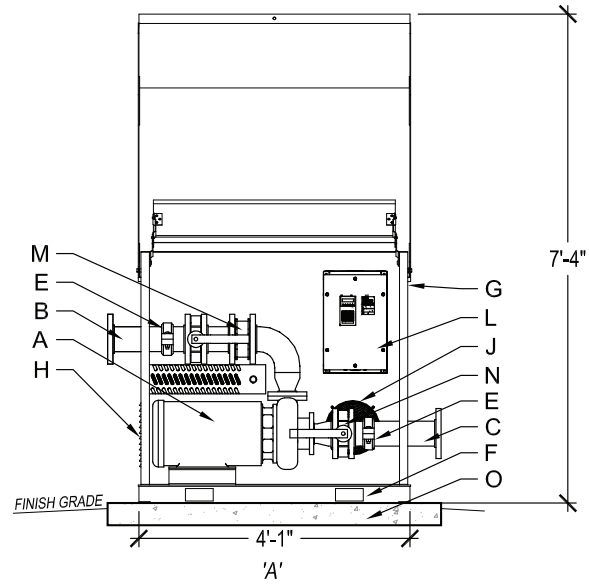

- NOTES:
- SLOPE FINISH GRADE AWAY FROM PUMP STATION / CONCRETE PAD
 - SECURELY ANCHOR PUMP STATION TO CONCRETE PAD

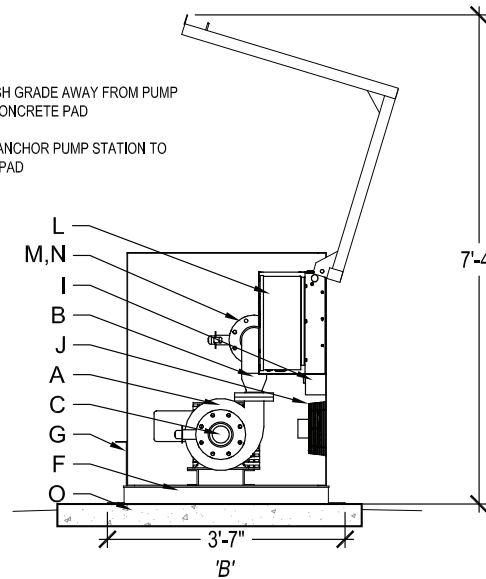

Specification Data: Skid Mounted Pumping System, consisting of an aluminum enclosure, close coupled motor driven pump, suction and discharge points of connections, pressure transducer, Variable Frequency Drive (VFD), disconnect switch and associated fittings. All Monsoon Force Series Pump Stations come in 208 Volt, 240 Volt and 480 Volt, three phase power.

Application: Monsoon Force Series Skid Mounted Pumping System is to be used on any project where water needs to be moved. Common applications include Irrigation Systems, Rain Water Harvesting, and commercial water features/fountains. This series can be configured as flooded-suction, suction-lift, or booster pumps. All Monsoon Force Series Pump Stations are built and tested at the factory for the highest degree of quality.

Available on request: Standard construction details and architectural specifications.

Monsoon Force Series 15HP

| PSI | GPM |
|-----|-----|
| 65 | 120 |
| 32 | 600 |

Monsoon Force Series 20HP

| PSI | GPM |
|-----|-----|
| 72 | 160 |
| 47 | 580 |

Monsoon Force Series 25HP

| PSI | GPM |
|-----|-----|
| 86 | 140 |
| 58 | 610 |

Monsoon Force Series Pump Curve

15 HP, 20 HP, 25 HP

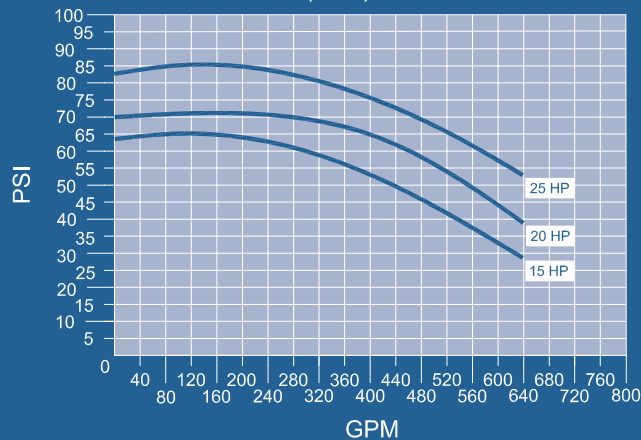

Final Pump Horse Power to be sized by inCon-trol.

Use graph for preliminary sizing only.

Three Phase Electrical Data

| HP | Voltage | Service Size |
|----|---------|--------------|
| 15 | 208 | 80A |
| 20 | 208 | 100A |
| 25 | 208 | 125A |
| 15 | 240 | 70A |
| 20 | 240 | 90A |
| 25 | 240 | 110A |
| 15 | 480 | 40A |
| 20 | 480 | 50A |
| 25 | 480 | 60A |

MONSOON FORCE SERIES



DEDICATED TO
EXCELLENCE
ON EVERY JOB

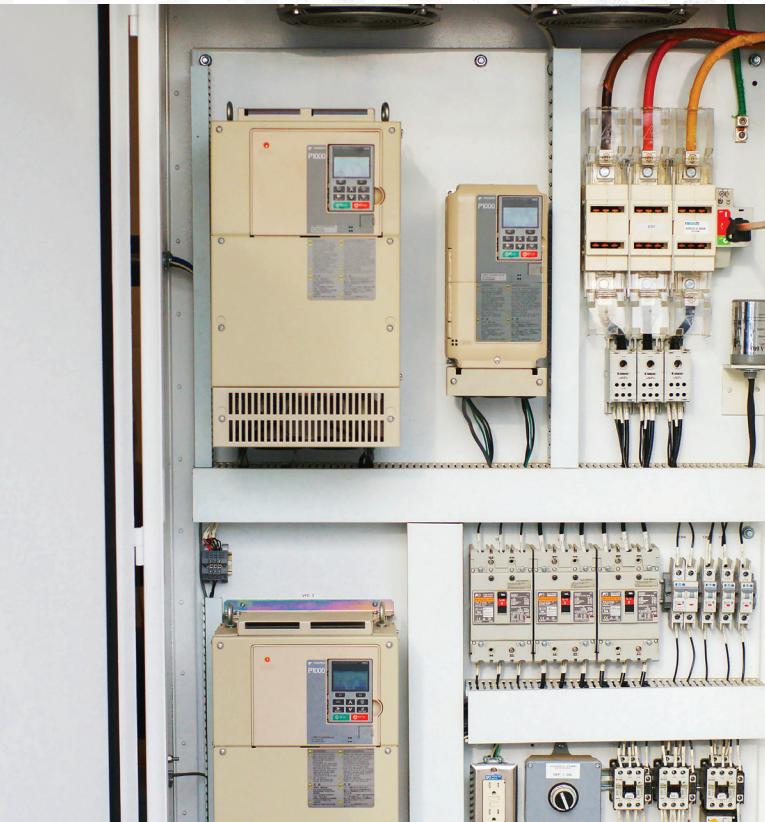

All electrical panels are designed, built, & programmed by inCon-trol (Certified UL 508A Panel Shop).



Water Feature Pumps & Pump Stations.



Custom fabrication and project/product mock-ups.

WE WANT TO BE
THE **ONLY SOURCE**
FOR YOUR WATER FEATURES & SYSTEMS
MANUFACTURING
NEEDS



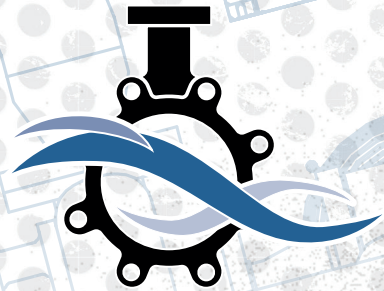

inControl
water systems

www.incontrolwatersystems.com

410 INTERCHANGE ST, MCKINNEY, TX 75071

214.733.8828