

INCON-TROL WATER SYSTEMS, GALE FORCE SERIES, IRRIGATION PUMP STATION. POWER TO BE PROVIDED BY OWNER TO PUMP STATION CONTROL PANEL, AND ELECTRICAL CONNECTION TO THE CONTROL PANEL BY OTHERS. PUMP STATION SHALL BE PRESSURE ACTIVATED, AND REQUIRES NO ELECTRICAL CONNECTION TO THE IRRIGATION SYSTEM. CONTACT INCON-TROL WATER SYSTEMS AT 214.733.8828 (EXT. 1), FOR FURTHER INFORMATION.

(PUMP STATION SHALL INCLUDE (1) PUMP/MOTOR, CONTROL PANEL, VARIABLE FREQUENCY DRIVE, LIGHTNING / SURGE ARRESTOR, PRESSURE ACTIVATED START AND HEATED/INSULATED ALUMINUM ENCLOSURE).

ELECTRICAL SERVICE TO BE PROVIDED BY OWNER.  
BREAKER SIZE TO BE PROVIDED BY INCON-TROL.

**NOTES:**

- PUMP STATION PLUMBING SHALL BE STEEL, PAINTED WITH DIRECT TO METAL CORROSION RESISTANT PAINT
- SLOPE FINISH GRADE AWAY FROM PUMP STATION / CONCRETE PAD.
- SECURELY ANCHOR PUMP STATION TO CONCRETE PAD.

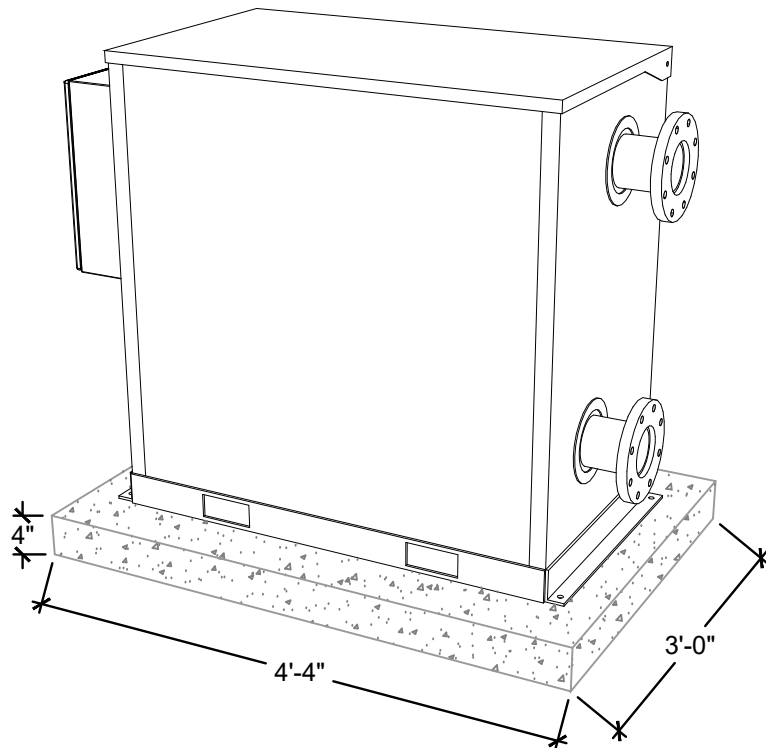

**INCON-TROL WATER SYSTEMS: GALE FORCE SERIES**

- A. CLOSE COUPLED PUMP/MOTOR
- B. DISCHARGE PLUMBING - STEEL FLANGE P.O.C.
- C. SUCTION PLUMBING - STEEL FLANGE P.O.C.
- D. CHECK VALVE
- E. BUTTERFLY VALVE
- F. PRESSURE TRANSDUCER
- G. PRESSURE GAUGE
- H. GRUVLOK STEEL COUPLING
- I. ALUMINUM PUMP SKID
- J. ALUMINUM ENCLOSURE (INSULATED)
- K. CONTROL PANEL
- L. HEATER
- M. FAN
- N. REINFORCED CONCRETE PAD

\*PUMP STATION SHALL BE PRESSURE ACTIVATED, AND REQUIRES NO ELECTRICAL CONNECTION TO THE IRRIGATION SYSTEM.\*



REQUIRED GPM: \_\_\_\_\_ REQUIRED PSI: \_\_\_\_\_

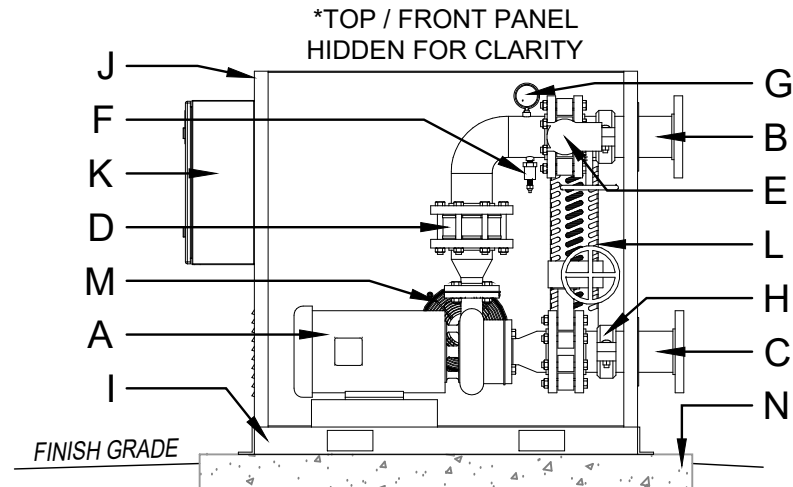

## GALE FORCE SERIES PUMP CURVE 5 HP, 7.5 HP, 10 HP

3 PHASE ELECTRICAL DATA		
HP	VOLTAGE	SERVICE SIZE
5	208	40A
7.5	208	50A
10	208	60A
HP	VOLTAGE	SERVICE SIZE
5	240	40A
7.5	240	50A
10	240	60A
HP	VOLTAGE	SERVICE SIZE
5	480	20A
7.5	480	25A
10	480	30A

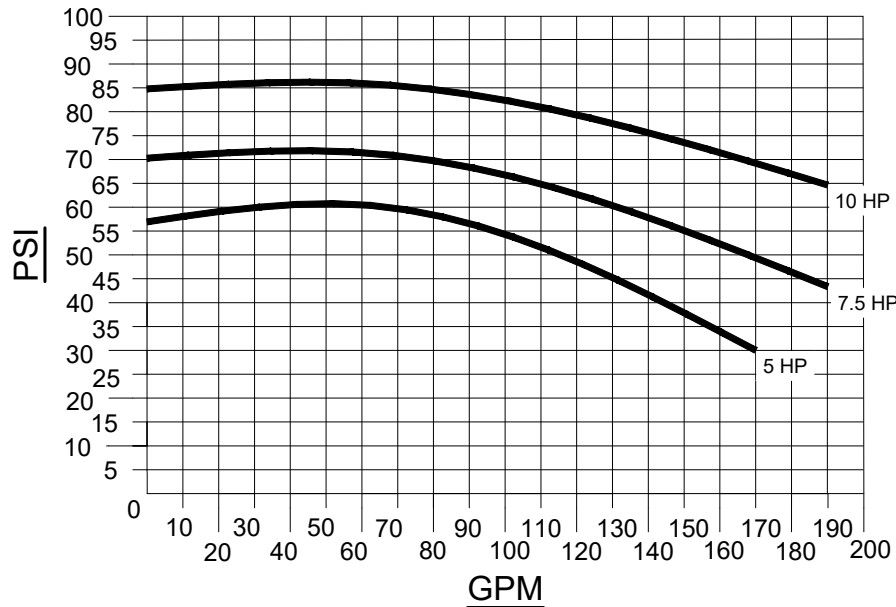

1 PHASE ELECTRICAL DATA		
HP	VOLTAGE	SERVICE SIZE
5	208	60A
7.5	208	70A
10	208	100A
HP	VOLTAGE	SERVICE SIZE
5	240	50A
7.5	240	70A
10	240	90A
HP	VOLTAGE	SERVICE SIZE
5	480	30A
7.5	480	40A
10	480	50A

GALE FORCE SERIES 5HP	
PSI	GPM
60	60
30	170

GALE FORCE SERIES 7.5HP	
PSI	GPM
72	60
43	190

GALE FORCE SERIES 10HP	
PSI	GPM
85	60
65	190

**FINAL HORSEPOWER TO BE SIZED BY INCON-TROL WATER SYSTEMS. USE GRAPH FOR PRELIMINARY SIZING ONLY.**

**SPECIFICATION DATA:** SKID MOUNTED PUMPING SYSTEM, CONSISTING OF AN ALUMINUM ENCLOSURE, CLOSE COUPLED MOTOR DRIVEN PUMP, SUCTION AND DISCHARGE POINTS OF CONNECTIONS, PRESSURE TRANSDUCER, VARIABLE FREQUENCY DRIVE (VFD), DISCONNECT SWITCH AND ASSOCIATED FITTINGS. ALL **GALE FORCE SERIES** PUMP STATIONS COME IN 208 VOLT, 240 VOLT AND 480 VOLT, (SINGLE & THREE PHASE) POWER.

**APPLICATION:** **GALE FORCE SERIES** SKID MOUNTED PUMPING SYSTEMS IS TO BE USED ON ANY PROJECT WHERE WATER NEEDS TO BE MOVED. COMMON APPLICATIONS INCLUDE IRRIGATION SYSTEMS, RAIN WATER HARVESTING, AND COMMERCIAL WATER FEATURES/FOUNTAINS. THIS SERIES CAN BE CONFIGURED AS, FLOODED-SUCTION, SUCTION-LIFT, OR BOOSTER PUMPS. ALL **GALE FORCE SERIES** PUMP STATIONS ARE BUILT AND TESTED AT THE FACTORY FOR THE HIGHEST DEGREE OF QUALITY.



REVISIONS
_____ X
_____ X

# GALE FORCE SERIES DETAIL SHEET

TITLE	Detail Sheet
DATE	09/01/2023
SCALE	1/2" = 1'-0"
SHEET	1 of 1